

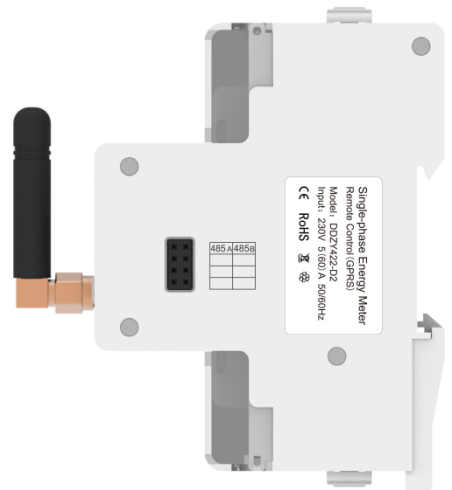

MODELO	ZSM-METER-1PH-2G	ZSM-METER-1PH-WIFI	ZSM-METER-3PH-2G	ZSM-METER-3PH-WIFI
Parámetros				
Dimensiones (mm)	110*76*36		91.5*85*36	
Sistema de montaje	35mm DIN montaje en carril		35mm DIN montaje en carril	
Comunicación con el servidor	2G (Tarjeta SIM y tráfico de datos de 10 años incluidos)	WI-FI	2G (Tarjeta SIM y tráfico de datos de 10 años incluidos)	WI-FI
Otras puertas	RS485		RS485	
Temperatura de trabajo	-40°C/+85°C		-40°C/+85°C	
Inserción (medura actual)	Inserción directa		Sensor de corriente incluido (sensores de núcleo dividido)	
Numero de sensores	NA		6	
Medida bidireccional	Si		Si	
Exactitud (%)	1		1	
Fuente de alimentación	Monofásico integrado 220V		380V integrado trifásico	
Voltaje nominal	220V		3x220V (380V Ph-Ph)	
Frecuencia nominal	50Hz/60Hz		50Hz/60Hz	
Corriente máxima nominal	60A		200A	
Potencia máxima nominal	13.2kW		132kW	
Consumo	3W		3W	

ZSM-METER-1PH-2G/WIFI

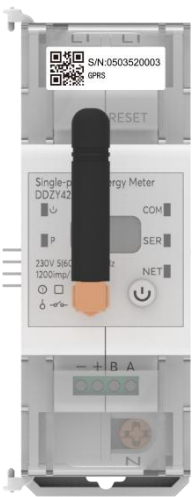

ESQUEMA DE INSTALACION PARA ZSM-METER-1PH-2G/WIFI

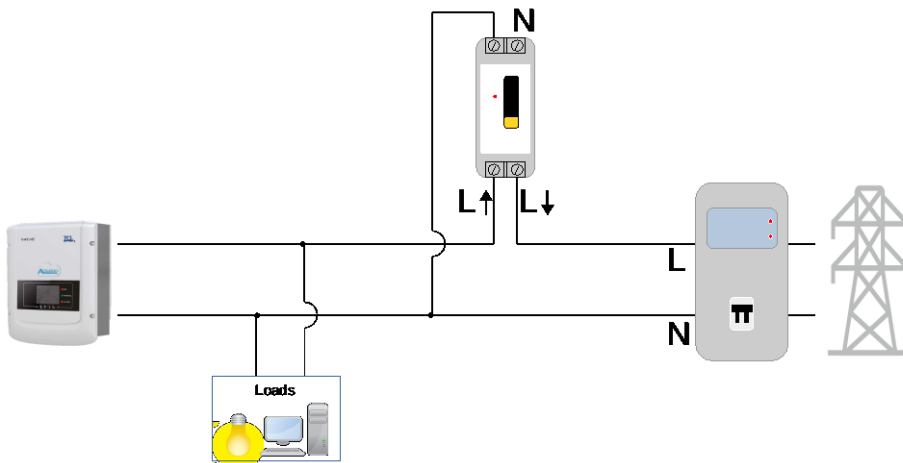

ZSM-METER-3PH-2G/WIFI

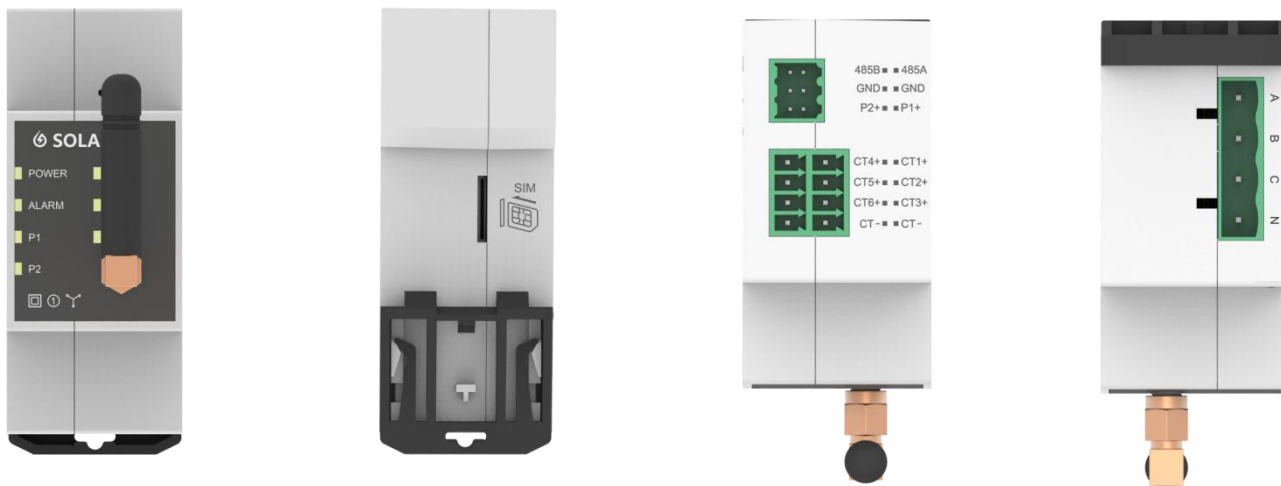

ESQUEMA DE INSTALACION PARA ZSM-METER-3PH-2G/WIFI

